

Housing $\phi 24 \times L30$ mm DC Brushless Motor B2430M

OUTPUT : 1W~8W (APPROX)

Bearing TYPE : スリーブ /Sleeve Bushing

WEIGHT(APPROX) : 51g

代表的用途 /Typical Application

家電機器 / 白物家電、調理家電、ファン、理美容家電 / 事務機器 / プリンタ、スキャナ、プロジェクタ / 医療・計測機器 / ポンプ、血圧計、攪拌器、分離器 / DIY / 電動ポンプ

Household App / Home Electric App, Electric Cooker, Fan, Shaver, Hair Curler

Office Automation Equipment / Printer, Scanner, Projector

Medical App / Medical Pomp, Blood Pressure Meter, Medical Stirrer/ DIY App / Electric Pump, Screw Driver



Characteristic : CW/CCW, Signal function available(FG), PWG speed control, Locked rotor protection, IC Heat protection, Life expectancy 10,000-30,000hrs,

Motor Parameter

No.	Standard Model No.	Product No.	Outline Size			Rated Voltage (V)	No Load		at Max Efficiency					at Stall			Configuration
			Motor OD (mm)	Housing Length (mm)	Start OD (mm)		No Load Speed (rpm)	No Load Current (A)	Rated Speed (rpm)	Rated Current (A)	Rated Torque		Output (W)	Starting Torque		Starting Current (A)	
											(mN-m)	(g · cm)		(mN-m)	(g · cm)		
10	B2430M	-S01	24.2	30.8	2	6	5380	0.23	4720	0.61	3.9	40.0	1.94	13.20	134.6	1.50	bushing
11		-S02	24.2	30.8	2	12	7900	0.20	6000	0.62	9.8	99.9	6.20	31.50	321.2	1.50	bushing
12		-S03	24.2	30.8	2	24	6600	0.07	5750	0.21	4.9	50.1	3.01	37.60	383.4	1.20	bushing

OUTLINE & Inner Driver I/O

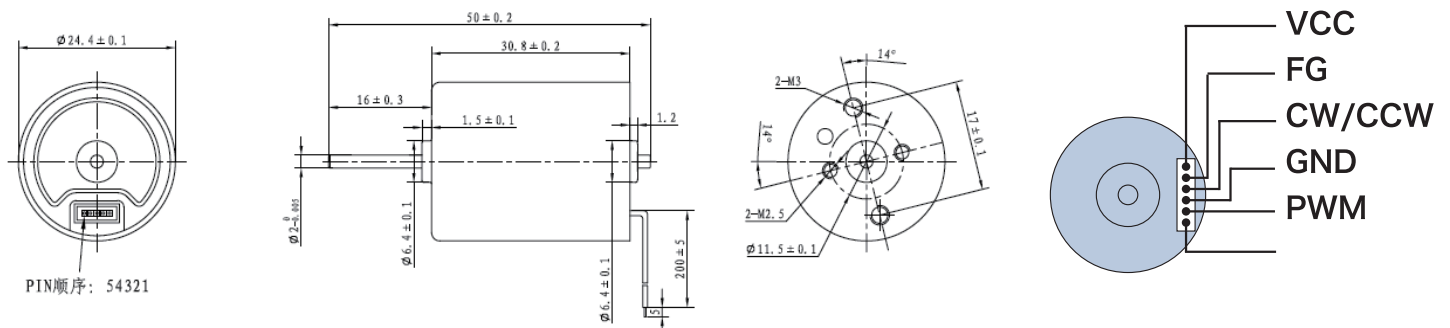

Typical Performance

B2430M-S02 (12V)

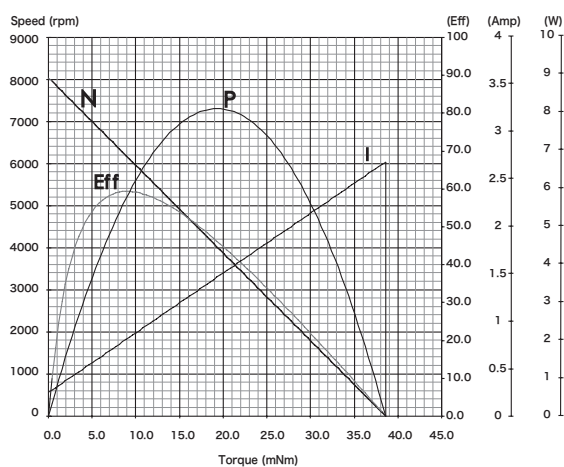

B2430M-S03 (24V)

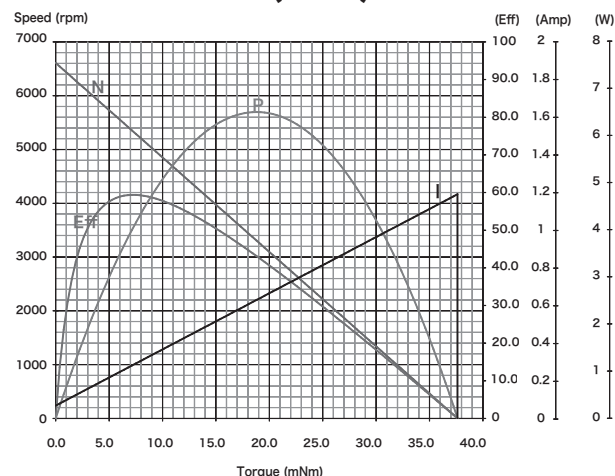

Japan Magnets, Inc

Head Office / Japan Bldg 4F, 1-1646-2, Kamikawa, Suwa, Nagano, Japan zipcode 392-0021

Tel /+81-266-56-1021

Fax /+81-266-56-1430

HP / <http://www.jmi-motion.com>